

MOTOROLA
Test Equipment

FM SIGNAL GENERATOR

MODELS S1318A
S1319A
S1320A
S1321A
S1329A



GUARANTEED PERFORMANCE SPECIFICATIONS

FREQUENCY ACCURACY	Each range is individually calibrated to an accuracy of $\pm 0.5\%$. Electronic fine tuning with or without modulation; ± 20 kHz frequency shift at 470 MHz. Incremental tuning range ± 16 kHz.
OUTPUT VOLTAGE, RF OSCILLATOR	Continuously variable from 0.1 microvolt to 100,000 microvolts (also calibrated from -8 dbm to 128 dbm) across 50-ohm termination. On 890-960 MHz band output is approximately 2000 microvolts per individually calibrated chart.
AUTOMATIC REFERENCE LEVEL	No manual adjustment necessary. Accurate to $\pm 10\%$ from 25 MHz to 470 MHz.
FREQUENCY STABILITY	Less than 0.001% frequency shift (short term, 5 minute stability) after 1-hour warm-up.
MODULATION FREQUENCIES	Internal: 1 kHz, $\pm 2\%$ sinewave. 20 Hz sawtooth sweep. dc incremental Note: Internal modulation signals available at EXT MOD connector. External: dc to 20 kHz (1 volt rms required for 16 kHz deviation).
OUTPUT VOLTAGE, IF OSCILLATOR	(Model S1318A only): Maximum output better than 0.5 volt into a 50-ohm resistive load (crystal position 0.3 volt). A front panel potentiometer gain control provides at least 50-to-1 attenuation.
MODULATION FIDELITY	Within 1 db to 15 kHz.
MODULATION DISTORTION	Less than 3% at 16 kHz deviation.
DEVIATION	± 16 kHz peak. Direct reading on panel meter for all ranges. Accuracy $\pm 10\%$.
SHIELDING	Double shielding for oscillator unit and multisection, individually-shielded rf filters reduce stray leakage to extremely low value. Carrier leakage is negligible.
RESIDUAL MODULATION	Less than 100 Hz at 460 MHz.
POWER SUPPLY	115/230 v ac, 50-60 Hz, 21 watts power consumption.
WEIGHT	27 lbs. with cover.
DIMENSIONS	11-1/2" high x 15-1/8" wide x 10-3/4" deep.
The instrument is supplied complete with front cover and detachable line cord. Output cable and termination pad are optional and must be ordered separately.	

SPECIFICATIONS SUBJECT TO CHANGE WITHOUT NOTICE

FOREWORD

SCOPE OF INSTRUCTION MANUAL

The equipment covered in this instruction manual was manufactured for Motorola Communications & Electronics Inc. by Measurements Division, Daven Corporation, Manchester, New Hampshire. The information in this manual is based on data supplied by the manufacturer and is reproduced with their permission.

NOMENCLATURE

Motorola test equipment is specifically identified by the model number on the nameplate. Be sure to use the entire model number when making inquiries about your equipment.

INSTRUCTION MANUAL REVISIONS

Changes which occur after an instruction manual is printed are described in the Instruction Manual Revision. These bulletins give the reader complete information on the change including pertinent parts listing data.

STORAGE

Remove dust from controls and outer surface of instrument with a clean rag. Wrap instrument in heavy wrapping paper and seal seams with gummed tape or similar adhesive. Store in a dry place. If excessive humidity is unavoidable, the wrapped instrument should be placed in a moisture-proof bag with a sufficient quantity of drying agent, such as silica gel, to insure a dry atmosphere. When the use of bag and desiccant is necessary, the instrument should be checked at six-month intervals to determine the effectiveness of the seal.

SHIPMENT

Wrap the instrument with a heavy wrapping paper and seal seams with gummed tape or similar adhesive. Place in fibre-board carton or wooden box large enough to permit at least three inches of excelsior or similar packing material between the instrument and sides of the box. For

export packing, the instrument must be wrapped in water-proof paper and the seams sealed with water-proof glue or similar sealing compound before being placed in a wooden box.

PARTS AND SERVICE

CAUTION

Read the "Maintenance Precautions" section of this manual before attempting to open or service the FM frequency generator. Only maintenance procedures specifically covered in the manual may be performed in the field without danger of serious damage to the equipment. If any other maintenance is required for this instrument, pack the instrument as indicated above and ship to the nearest Motorola Parts Depot.

When ordering replacement parts, the complete number identification of the item must be used. Orders for instruction manuals should also be sent to the parts depot. Motorola Parts Depots are located at the following addresses:

2333 Utah Ave., El Segundo, California 90245

1170 Chess Drive, San Mateo, California 94404

Lake Mirror Road, Forest Park, Georgia 30050

1313 E. Algonquin Road, Schaumburg, Ill. 60172

85 Harristown Road, Glen Rock, New Jersey 07452

12955 Snow Road, Parma, Ohio 44130

3220 Belt Line Road, Dallas, Texas 75234

CONTENTS

<u>SECTION</u>	<u>PAGE</u>
Guaranteed Performance Specifications	ii
DESCRIPTION	1
ACCESSORIES AND AUXILIARY EQUIPMENT	2
CONTROL FUNCTIONS	2
OPERATING PROCEDURE	4
INSTRUMENT CHECKOUT PROCEDURE	5
MAINTENANCE.	5
SERVICE DIAGRAMS	
IF and Crystal Oscillator Schematic Diagram63E81061A77
FM Signal Generator Circuit Board DetailsPEPD-23090
FM Signal Generator S1318A, S1319A, S1320A, and S1321A Schematic Diagram63E81061A76
FM Signal Generator S1318A-1, S1319A-1, S1320A-1, S1321A-1, and S1329A-1 Schematic Diagram.63P81020E16

MOTOROLA

FM SIGNAL GENERATOR

MODELS S1318A
S1319A
S1320A
S1321A
S1329A

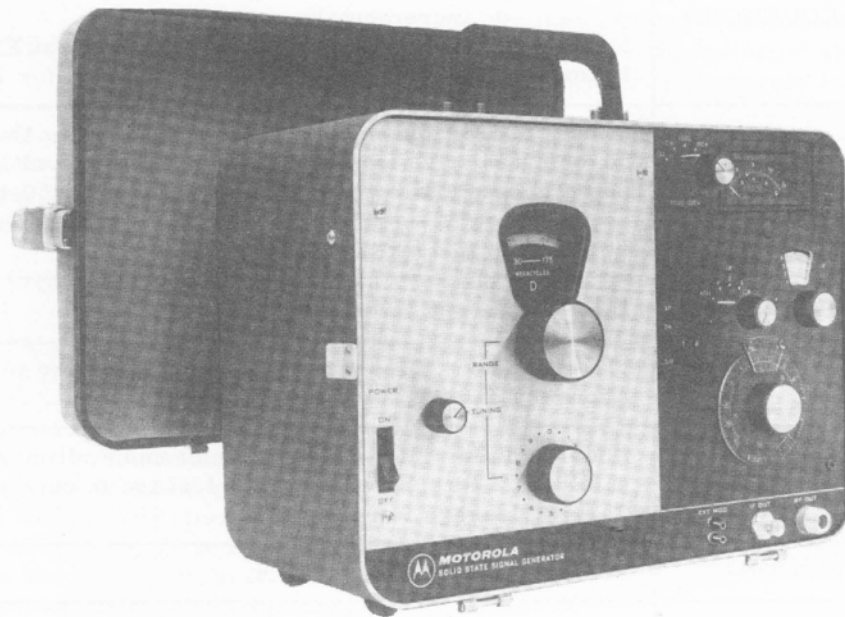

Model S1318A



MOTOROLA INC.

ENGINEERING PUBLICATIONS

1301 E. ALGONQUIN ROAD

Communications Division

SCHAUMBURG, ILLINOIS 60172

Copyright 1973 by Motorola, Inc.
Printed in U. S. A.
4/30/73-RS

68P81061A75
Issue - A

MODEL TABLE

MODEL	RF BANDS						IF BANDS **
	A	B	C	D	E	F	
S1318A	25-32 MHz	32-41 MHz	41-54 MHz	130-175 MHz	400-470 MHz	890-960 MHz*	XTAL 1, 2, 3, 4.
S1319A	25-32 MHz	32-41 MHz	41-54 MHz	130-175 MHz	400-470 MHz	890-960 MHz*	--
S1320A	25-32 MHz	32-41 MHz	41-54 MHz	68-88 MHz	130-175 MHz	400-470 MHz	--
S1321A	25-32 MHz	32-41 MHz	41-54 MHz	68-88 MHz	88-115 MHz	130-175 MHz	--
S1329A	25-32 MHz	32-41 MHz	41-54 MHz	130-175 MHz	400-470 MHz	470-512 MHz	--

**See Separate IF Range Table.

*Second Harmonic of 445-480 MHz.

1. DESCRIPTION

a. Radio Frequency Section

The four Motorola FM signal generator models shown in the above table differ only in frequency range coverage. Each model has six switchable rf frequency ranges. The primary signal is generated by a double shielded nuvistor oscillator circuit. The output has a mutual inductance attenuator of the waveguide-below-cut-off type. This output is calibrated in terms of the voltage developed across a 50-ohm resistive termination. The output voltage level is continuously monitored by a temperature-compensated barretter bridge. The output of the barretter bridge controls an automatic level adjusting circuit. The modulator is a 1000-Hz Wein bridge RC oscillator using variable-capacitance diodes. Peak deviation may be varied from zero to 16 kHz. Internal dc modulation voltages provide metered incremental carrier shifts up to 16 kHz each side of the carrier. An internal 20 Hz saw-tooth generator provides continuously adjustable metered sweep width up to 32 kHz peak-to-peak.

b. Power Supply Section

A regulated dc power supply is used for the nuvistor tube plate supply and for transistor bias supplies. The power transformer has four output windings. One winding is used for the 6.3-volt ac pilot lamps. A 14.5-volt ac winding feeds a bridge rectifier, CR3. A single series rectifier transistor (Q4) takes its sense voltage from Zener diode CR4 and the 12-volt adjust control R17. The filtered series output is connected to the +12-volt supply line and serves as a regulated sense voltage for the negative 6-volt supply. The negative supply is taken from a 10-volt ac winding and a bridge

rectifier. A voltage sense transistor (Q1) takes its sense voltage from the negative supply adjust control R5 in the output divider (with R4 and R6). Q1 feeds the driver Q2 which feeds the series regulator Q3. The filtered regulated output of this supply is a negative 6.3 volts dc.

The high voltage supply is taken from a 125-volt winding and a bridge rectifier. Q6 compares the divider voltage from the output with the fixed reference voltage at the plate of V1 voltage regulator tube. Q6 also controls the series regulator transistor Q7. In case of a short circuit of the output, Q5 conducts to saturation and cuts off the regulator. This serves to protect the nuvistor tube. R14 on the divider is the adjustment control for the 115-volt dc output.

c. Intermediate Frequency Section

The S1318A Signal Generator is the only model which includes an independent i-f signal generator. Two crystal sockets accommodate the most commonly used crystal pin spacing. Use of crystal control provides highly stable i-f frequency output in the 250 kHz to 1 MHz range. Refer to the following IF Frequency Range Table for the additional (non-crystal controlled) ranges.

IF Frequency Range Table

BAND	RANGE
1	2.4-3.9 MHz
2	3.9-6.0 MHz
3	6.8-9.4 MHz
4	69.0-76.0 MHz

Note: For i-f frequencies not in the above bands use on harmonics. For example, for 12 MHz, use 6 MHz, etc.



TEKA-16
Canvas Cover



AEPD-23107-O

TEKA-64
Carrying Case



AEPS-11386-O

SKN6020A
Cable

2. ACCESSORIES AND AUXILIARY EQUIPMENT

a. Accessories

(1) Model SLN6329A Output Matching Pad; 6 db loss, with Type N Input Connector and UHF Output Connector.

(2) Model SLN6330A Output Matching Pad; 6 db loss, with Type N Input Connector and Type N Output Connector.

(3) Model SKN6019A Cable; 4 ft. of RG-55/U with Type UHF Connectors at both ends.

(4) Model SKN6020A Cable; 4 ft. of RG-55/U with Type N Connectors at both ends.

(5) Model TEKA-16 Case; #10 cotton duck canvas, hood-type protective cover.

(6) Model TEKA-64 Case; heavy duty carrying case with reinforced corners for maximum protection.

b. Auxiliary Equipment

(1) Measurements Model 202-C Standard Barretter Bridge.

(2) Measurements Model 111-B Crystal Calibrator.

(3) Motorola Model S1323A Standard Deviation Meter.

(4) Motorola Model S1063A DC Multimeter or equivalent high impedance meter.

(5) Motorola Model S1051C AC Voltmeter or equivalent.

3. CONTROL FUNCTIONS

a. POWER

(1) The ON-OFF switch controls the application of line voltage to the primary of the power transformer.

(2) A fuse located at the rear of the unit protects against overloads (1/4 amp for 115-volt ac operation or 1/8 amp for 230-volt ac operation).

b. TUNING Dial

(1) The RANGE knob selects one of the six available frequency ranges. The range letter and frequency appears in the window above the knob as it is rotated.

(2) The coarse TUNING knob sets the desired carrier frequency. The frequency is indicated under the fiducial line in the panel opening directly above the RANGE knob. The frequency dial will automatically disengage when the usable part of the tuning range has been passed. To facilitate selectivity measurements about any center frequency, the frequency dial may be disengaged from the tuning mechanism by pressing the coarse TUNING knob to the right. The coarse TUNING knob may then be rotated so that it may be placed at zero with reference to its calibration marks.

(3) The fine TUNING knob electronically fine tunes the oscillator.

c. EXTERNAL MODULATION

(1) The EXT MOD binding posts located at the bottom of the panel permit the application of an external signal for frequency modulation of the carrier.

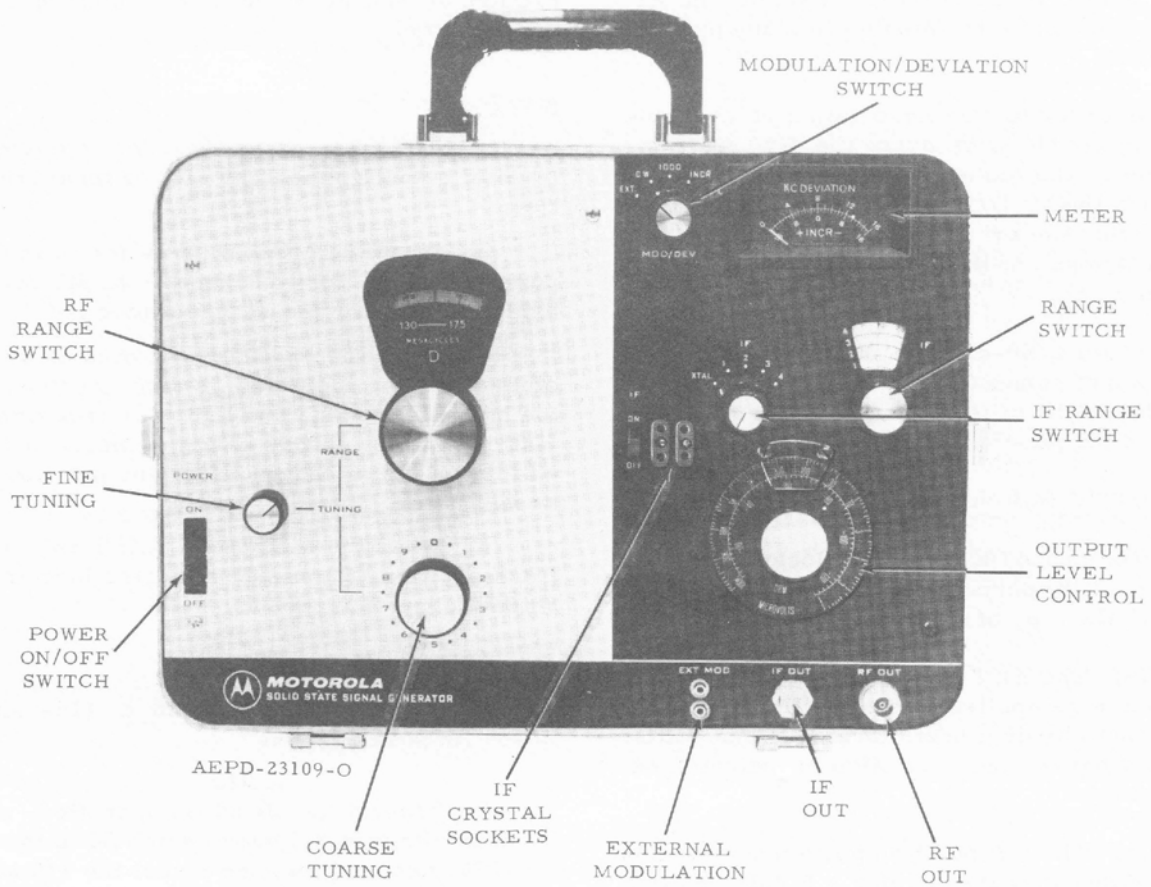

(2) Approximately 16 kHz FM deviation is produced per 1.0 v rms of modulating signal. The deviation is indicated on the panel meter.

d. Output Level Control

(1) The output control is a dial calibrated in MICROVOLTS and DBM. This dial adjusts the position of the output loop in the piston attenuator and will indicate the true output in MICROVOLTS (100, 000 to 0.1) or DBM (-8 to -128) when the RF OUTPUT connector is terminated in a 50-ohm resistive load.

(2) In order to check the output rf level, the MOD/DEV switch must be in the CW position. This connects the meter to the output bridge circuit. When the MOD/DEV switch is in any other position, the meter is disconnected from the barretter bridge and is used to indicate frequency deviation.

(3) When a 50-ohm, 6 db pad is connected between output connector and 50-ohm load resistor, the output level is read directly beneath the pad line on the plastic fiducial.

e. MOD/DEV Switch

(1) The MOD/DEV switch is located adjacent to the meter. Its purpose is to supply the carrier signal with the type of modulation desired.

(a) The EXT position allows external modulation to be applied to the oscillator via the two EXT MOD binding posts located at the bottom of the front panel. The deviation is indicated on the panel meter.

(b) The CW position provides an unmodulated continuous-wave carrier. In this position the panel meter is connected to the bolometer bridge for rf voltage level checking.

(c) The 1000 Hertz position applies approximately 1 v rms to the modulator input for internal 1000 Hz modulation.

(d) The INCR position permits incremental adjustment of the carrier frequency.

(e) The  (saw-tooth) position applies a sweep voltage to the modulator input for internal modulation. The saw-tooth waveform is also available from the EXT MOD binding posts for application to the horizontal or sync input of an oscilloscope.

f. Deviation Control

(1) The deviation control is a potentiometer which controls frequency deviation when either internal or external modulation is employed. It also adjusts incremental frequency shift. It is operated by the smaller knob on the MOD/DEV switch.

(2) The frequency (KC DEVIATION), or incremental frequency shift, is indicated on the panel meter.

g. Meter

(1) The meter is used to check the reference level of output voltage and also to measure deviation.

(2) When the MOD/DEV switch is in the CW position, the meter is connected to the barretter bridge to monitor the rf output level.

(3) When the MOD/DEV switch is in any other position, the meter is disconnected from the barretter bridge and indicates frequency deviation in kHz. In this case the meter is connected to a crystal diode rectifier and operates as an ac voltmeter.

(4) When the MOD/DEV switch is in the INCR position, the meter indicates incremental shift in carrier frequency.

4. OPERATING PROCEDURE

a. Connect the power cord to a 115-volt ac 50-60 Hz power source.

NOTE

For 230-volt ac 50-60 Hz operation, set Line Voltage Selector switch S4 to the 230-volt position; and insert the 1/8 ampere, 230-volt fuse in the power supply chassis.

b. Place the POWER ON-OFF switch in the ON position. Allow about ten minutes for the instrument to become stabilized.

c. Rotate the RANGE knob to select the desired frequency band.

d. Set the coarse TUNING knob to the desired carrier frequency and adjust the fine TUNING knob as necessary for critical frequency adjustment.

e. Turn the MICROVOLTS dial to the desired output voltage as indicated under the fiducial line.

f. To frequency modulate the carrier, set the MOD/DEV switch to EXT, 1000, INCR, or "saw-tooth" as desired. Rotate the deviation control to the desired kHz DEVIATION as indicated on the meter.

g. To frequency modulate the carrier using external modulation, connect the modulating signal to the EXT MOD binding posts. This signal should be approximately 1V rms to produce the full 16 kHz of deviation. Set the MOD/DEV switch to EXT and rotate the deviation control to desired kHz DEVIATION as indicated on the meter.

h. If incremental control of carrier frequency is desired, set the MOD/DEV switch to INCR. The deviation control adjusts the frequency shift, as indicated on lower scale of the meter.

i. For all frequency bands, the deviation in kHz is indicated on the panel meter to an accuracy of $\pm 10\%$ of full scale.

5. INSTRUMENT CHECKOUT PROCEDURE

NOTE

Use this procedure when the instrument is received and periodically thereafter to check performance.

- a. Following the "Operating Procedure", allow the instrument to stabilize for about 10 minutes.
- b. Set the MOD/DEV switch in the CW position and the RANGE switch to the lowest scale. The meter pointer should rest on zero on the meter dial (deviation scale).
- c. Repeat step "b" for each frequency range.
- d. Place the MOD/DEV switch in the 1000 position and rotate the deviation control knob from fully counterclockwise to fully clockwise. The meter pointer should deflect from zero to full scale.

6. MAINTENANCE

CAUTION

Refer to the precaution steps in this section before attempting to service the signal generator.

The purpose of this section is to acquaint operating and maintenance personnel with procedures for making certain adjustments that may be necessary after a tube or critical part is replaced.

It should be noted that most of the field replaceable parts are available from Motorola. Use Motorola part numbers when ordering. Pre-tested and preadjusted plug-in printed circuit boards are also available. These generally require very slight readjustment after installation. The adjustment procedures outlined in this section should be carefully followed.

a. Precaution

Observe the following precautions if the unit is opened for service:

(1) Do not attempt to readjust any controls not specifically described in the following paragraphs.

(2) Do not use an ohmmeter or other source of current without first unsoldering one terminal of each of the bolometer assemblies. These bolometer elements are easily burned out and difficult to replace.

(3) The instrument should not be grounded during a soldering operation because of possible electrical leakage in soldering irons.

(4) Exposed portions of the calibrated carrier frequency dial should be protected against handling. No liquids should be used for cleaning this dial.

b. Removing the Instrument From the Case

(1) Disconnect the power cord from the ac source.

(2) Turn the MICROVOLTS dial clockwise to the 100,000 microvolts position.

(3) With the instrument in its normal upright position, remove six Phillips head screws nearest the front edge of the case. Two on each side, one on the top and one on the bottom. Break the sealing wax on the bottom screw. The front section of the instrument is now free of the case except for the cable connecting it to the power supply chassis.

(4) Gently tip the top of the instrument forward so that the edges of the front panel may be grasped with the hands. Remove the instrument from the case.

(5) Lay the instrument face down, supporting the edges of the panel on a pair of 2" x 4" wood blocks or equivalent. Allow clearance so that no weight rests on the control knobs.

(6) The power supply assembly may be removed from the case by removing the six Phillips head screws holding it into the case.

c. Removing the Front Panel

(1) Place the instrument with the top edge of the panel down.

(2) Remove the RANGE, coarse and fine TUNING and MOD/DEV knobs.

(3) Remove the clear plastic fiducial which is located above the MICROVOLTS dial. Remove the MICROVOLTS dial.

(4) Remove the connections from the EXT MOD posts.

(5) Disconnect the leads from the meter. Mark the leads so that they may be properly replaced.

(6) Remove the six Phillips head 6-32 screws (2 nickel and 4 black) from the face of the panel. The front panel is now free of the front section.

d. Lamp Replacement

(1) For meter lamp replacement remove the instrument from the case. Remove the bayonet 6-volt lamp and replace with a #44 lamp or equal.

(2) For carrier frequency dial lamp replacement remove the instrument from the case and remove the front panel. Remove the bayonet 6-volt lamp and replace with a #44 lamp or equal.

e. Power Supply Adjustment

(1) Remove the instrument and power supply from the case, exposing the numbered pin connections on the underside of the power supply connector mounted on the power supply chassis.

(2) With the instrument connected to the power supply, connect the power supply to an adjustable source of ac power.

(3) Adjust the ac line voltage to 115 volts (Note: Some instruments are prewired to operate on 230-volt ac - adjust accordingly).

(4) Switch instrument POWER switch "ON".

(5) Using an accurate ($\pm 3\%$ or better) high impedance VOM (20,000 ohms-per-volt suggested), measure and adjust the three power supply voltages

as indicated below. Do not readjust power supply voltages if within $\pm 3\%$ of nominal values. A slight change in adjustment could affect the adjustment of other circuits:

<u>Voltages</u>	<u>Test Point On Connector</u>	<u>Adjustment Control</u>
(adjust 1st) +115 volts dc	pt 3 to ground 4	+115V ADJ.
(adjust 2nd) +12 volts dc	pt 2 to ground 4	+12V ADJ.
(adjust last) -6.3 volts dc	pt 1 to ground 4	-6.3V ADJ.

(6) Vary the line voltage ± 15 volts ac. The +115-volt dc and +12-volt dc supplies will not vary noticeably over this range. The -6.3-volt dc supply will vary up to 0.1 volts dc.

(7) If a high sensitivity oscilloscope or ac meter is available, check residual hum and noise of the three power supplies:

- +115 volts dc - less than 5 mv rms.
- +12 volts dc - less than 1 mv rms.
- 6 volts dc - less than 1 mv rms.

NOTE

Adjustment of the power supplies affects many other adjustments throughout the instrument. It is important therefore, that the remainder of the measurements described in this section be performed and adjustments made as indicated.

f. RF Oscillator Tube Replacement

(1) Remove the strapholding the V101 Oscillator shield covers.

(2) Twist off the outer and inner shield covers. Tools must never be used to pry off these covers as even slight dents in the cans or covers may cause serious leakage of the carrier.

(3) Remove the lower screw from roller spring on top of the coil disc and retract the upper screw sufficiently to permit roller to be removed. Rotate the spring to clear the coil disc.

(4) Rotate coil disc to place detent roller midway between detent positions.

(5) Hold coil disc firmly and remove nut which secures the coil disc (use a 1" spanner wrench).

(6) Lift the detent roller clear of disc edge and carefully lift coil disc assembly from its hub. The oscillator tube V101 is now available for replacement. If possible, select a tube which has the least effect on the frequency calibration.

(7) Retract the detent roller, making certain its spring is engaged. Lower the coil disc in proper position to engage the flatted portion of the coil disc hub. Release detent roller against the edge of coil disc and rock disc until it is properly seated. Replace the coil disc nut and tighten firmly.

(8) Replace the roller, insert the lower roller spring screw and tighten both screws.

(9) Check alignment of the three coil contacts with their respective contact posts on the capacitor assembly since misalignment may cause serious damage.

(10) Replace the oscillator shield cans making certain that the factory marks line up on each cover and shield. Replace the holding strap.

g. RF Oscillator Voltage Variable Capacitor Replacement

CAUTION

The voltage variable capacitors used in this equipment have seldom been a cause of trouble. Although the voltage variable capacitors have often been suspected of causing noise, instability and even hum in the Signal Generator, the problems could almost invariably be traced to other causes. Installation and adjustment of the voltage variable capacitors is particularly critical and should only be performed after very careful consideration.

(1) Remove the rf oscillator shield covers and coil disc as described in Section f.

(2) Unsolder and replace the entire voltage variable capacitors assembly including C102 and C105 trimmer capacitors, voltage variable capacitors C103 and C104, and 150K resistors R103, R104, and R105. The trimmer closest to the panel (C102) should be preset to 5 pf., before the assembly is installed in the oscillator.

(3) Replace the coil disc assembly as described in paragraph 6. f.

(4) Set the Generator to "A" Range and set frequency to the "A" range frequency (shown on dial).

(5) Modulate the oscillator using the internal 1000 Hz modulation (set to 16 kHz deviation).

(6) Using an external Standard Deviation Meter such as Measurements Model 140A or Model 920, measure the actual deviation.

(7) Adjust trimmer C105 until the actual deviation measures 16 kHz.

NOTE

The voltage at the wiper of section 3 of the Deviation Band switch should measure 6 volts ac rms with approximately 55 volts dc bias and 16 kHz deviation. If not, set the deviation control to provide these voltages regardless of the internal modulation meter reading. Reset trimmer C105 to obtain 16 kHz deviation as measured on the external Deviation Meter. This will necessitate readjustment of the Deviation Adjust Potentiometers as outlined in paragraph 6. e. of this section.

h. RF Oscillator Bolometer Replacement

CAUTION

In testing the bolometer circuit, do not use an ohmmeter or other source of current without first unsoldering one terminal of each of the bolometer assemblies. The bolometer elements are easily burned out and difficult to replace.

The instrument should not be grounded during a soldering operation because of possible electrical leakage in the soldering iron.

(1) Remove the rf oscillator shield covers and coil disc as in Section f. exposing the bolometer block assembly.

(2) Make careful note of the lead-dress of the wires and cable leading to and from the bolometer block (including the wire passing through the sub-panel of the instrument).

(3) Disconnect the resistance wire insulated leads from the filter terminals by unsoldering carefully.

(4) Disconnect the wire which passes through the sub-panel to the rf choke by unsoldering the choke end.

(5) Remove the three 6-32 screws which attach the block to the shields and sub-panel.

(6) Gently remove the bolometer block, drawing the attached wire through the sub-panel. Allow the shielded cable to remain attached to the block.

(7) Unsolder the lead attached to the bolometer through the lead washer hole in the bottom of the block. Also detach the connection to the terminating resistor R109 through the access hole in the bottom of the block.

(8) Loosen the 4-40 Allen head set screws and slide the bolometer assemblies from the block.

(9) Reinstall repaired bolometer block assemblies into the block; resolder connections and retighten set screws. Reshape the lead washer slightly concave to assure positive seal of the shield and sub-panel hole.

(10) Reinstall the bolometer block. Tighten the three mounting screws evenly to assure tight lead washer seal.

(11) Reconnect all leads carefully and redress to minimize effects of leakage and spurious resonance.

(12) Reinstall the coil disc and the shield covers as described in Section f.

i. Automatic Output Board Adjustment

(1) Connect the rf output of the instrument through a Model SKN6020A Cable and Model SLN6330A 6-DB Pad to the input of a Measurements Model 202C Standard Barretter Bridge.

(2) Carefully adjust the mechanical zero of the signal generator.

(3) Disconnect the +115-volt dc lead from the rf filter capacitor C109. Insulate the lead from the grounded chassis.

(4) Connect the output of an external variable power supply to C109. The power supply should be capable of supplying up to 25 ma dc.

(5) Turn the generator POWER switch ON to provide filament voltage to the oscillator nuvistor tube V101.

(6) Set the output of the generator to 0.1 volts on the attenuator dial.

(7) Adjust the external power supply to provide a 50 microvolts reading on the barretter bridge.

(8) With the MOD/DEV switch in the CW position; adjust the OUTPUT ADJ pot on the incr. dist. printed circuit board until the meter reads zero.

(9) Short the input to the bases of Q701 (on the automatic output printed circuit board) together. CAUTION - Be extremely careful to not short either of these points to ground or to any other point on the socket. This could instantly destroy the bolometers in the rf oscillator circuit. Adjust the BAL control R708 for zero reading on the meter.

(10) Adjust BIAS control R704 for a reading of 75 volts dc as measured at the output of Q703 using an accurate high impedance meter. This voltage reading is available from the lead previously disconnected from C109.

(11) Turn the power OFF and remove the external power supply.

(12) Disconnect the short at the input to Q701.

(13) Reconnect the output lead to C109.

(14) Turn the power ON and test each range of the generator to see that the meter "zeros" in the CW position. The output voltage measured at C109 should vary within the range of 25 volts dc to 105 volts dc in the normal control of output level.

(15) If the readings on the Model 202C do not spread properly about the 50 microvolt reading, readjust the OUTPUT ADJ accordingly. Recheck the output throughout each frequency range.

j. Output (Incr. Dist. Board Pt. 3) Adjustment

(1) Check each frequency range of the generator with the MOD/DEV switch in CW to see that the Automatic Output Board and the rf oscillator are functioning properly.

(2) Connect the output of the generator through a Model SKN6020A Cable and Model SLN6330A 6-DB Pad to the input of a Measurement Model 202C Standard Barretter Bridge.

(3) Set the output level control of the generator to 0.1 volts (100K uv). The reading on the temperature stabilized and "zeroed" barretter bridge should be 50 uv \pm 10%.

(4) Check each frequency range of the generator for output voltage accuracy.

(5) Adjust the OUTPUT ADJ R309 located on the incr. dist. printed circuit board for optimum compromise of output accuracy over the frequency ranges of the instrument. Allow a few seconds after each adjustment for the automatic output circuit to stabilize.

k. Deviation Ampl. Board Adjustment

(1) Attach a meter such as Motorola Model S1063 Series to the collector of Q502 on the Dev. Ampl. Board. Set the meter to the +100V DC range.

(2) Turn the signal generator POWER switch ON.

(3) Turn the deviation control on the unit to maximum CCW in the EXT modulation position.

(4) Adjust BIAS II R508 for a reading of 45 volts on the meter.

(5) Turn the deviation control of the generator to mid-range and rotate the control back and forth about a quarter of a turn. Adjust BIAS I R507 for zero change in meter reading as the deviation control is rotated throughout its range.

(6) If necessary, readjust BIAS II R508 for a 45-volt reading.

(7) Repeat steps (5) and (6) until the conditions of reading 45 volts with zero effect from deviation control rotation are met.

(8) Switch MOD/DEV to the 1000 Hz position and increase the deviation control for a 16 kHz reading on the meter.

(9) The ac voltage at the base and collector of Q502 should be approximately 1 volt rms and 10 volts rms respectively.

l. Deviation Board Adjustment

(1) Attach an ac meter to the C124 filter capacitor on the shield can of the rf oscillator.

(2) Set frequency to "A" RANGE and the POWER switch ON.

(3) Connect the signal generator to a measurements Model 140A or Model 920 Standard Deviation Meter.

(4) Check to see that the actual deviation as measured with the Standard Deviation Meter matches the reading of the generator at 16 kHz. If not readjust "A" band DEV ADJ R611. The voltage measured by the ac meter should be approximately 6 volts ac and 55 volts dc. If not it probably will be necessary to readjust the rf oscillator voltage variable capacitors as outlined in paragraph 6. g.

(5) Measure deviation at 32 MHz on "A" Range and adjust R612.

(6) Alternately measure and adjust R611 and R612 until the deviation accuracy is compromised over the entire "A" Range.

(7) Accurately measure the dc voltage at C124.

(8) Adjust the DIST ADJ R307 located on the incr. dist. board PT2, until the voltage at the wiper of R307 exactly equals the voltage at C124.

(9) Repeat step (6), if necessary, to correct for the affect of the adjustment of the DIST ADJ R307.

(10) Repeat steps (7), (8), and (9) until all conditions are satisfied. Note that the DIST ADJ R307 will not have to again be adjusted throughout the remainder of the procedure.

(11) Set frequency to the "B" Range. Check deviation and adjust DEV ADJ R609, if necessary.

(12) Alternately measure and adjust R609 and R610 until the deviation accuracy is compromised over the entire "B" Range.

(13) Perform similar adjustments of Ranges "C", "D", and "E" with the associated DEV ADJS control until all are adjusted as in step (12) for "B" range.

(14) Perform similar adjustment for Range "F". (Note; on the 890-960 MHz range the actual deviation reading as measured by the Model 140A should be half of the indicated reading on the signal generator. This is due to the doubling effect in using the 2nd. harmonic as the calibrated output frequency in this range.)

m. Distortion (Incr. Dist. Board Pt2) Adjustment

NOTE

The adjustment of the DIST ADJ R307 normally affects the accuracy of "A" RANGE deviation. Distortion Adjustment should not be attempted except as part of the deviation board Adjustment procedure. Refer to paragraph 6.1.

n. Incremental (Incr. Dist. Board Pt 1.) Adjustment

(1) Attach a direct-coupled oscilloscope through a high impedance probe from the wiper of the deviation control R51 to ground.

(2) Establish a ground reference line at the vertical center of the oscilloscope.

(3) Switch the generator POWER switch ON and switch the MOD/DEV switch to the 1000 position. Set the deviation control to 16 kHz.

(4) Adjust the vertical sensitivity of the oscilloscope so that, with the ground at center, the tips of the sinusoid are set to the highest and lowest graticule lines. Full scale on the oscilloscope will now correspond to the "peak-to-peak" deviation of 32 kHz (note that the generator is calibrated in terms of "peak" deviation).

(5) Switch the MOD/DEV switch to the INCR position.

(6) Adjust INCR CENT R306 fully CCW.

(7) Rotate the deviation control to the point corresponding to ground on the oscilloscope. This should also cause a zero reading on the meter (-16 kHz on the INCR scale).

(8) Readjust the INCR CENT R306 for a "0" INCR reading on the meter.

(9) Adjust the INCR ADJ R304 so that full scale readings on the oscilloscope corresponds to full scale +16 kHz and -16 kHz on the generator meter when the deviation control is rotated.

(10) Repeat adjustment of the INCR CENT R306 and INCR ADJ R304 so that the full scale readings on the oscilloscope correspond to full scale +16 kHz and -16 kHz on the generator meter and also that the ground reading on the oscilloscope corresponds to zero on the meter. The

two adjustments are interdependent and generally require back and forth adjusting a few times until all of the three conditions are satisfied.

o. Audio Oscillator Board Adjustment

(1) Connect the high impedance probe of an oscilloscope to the EXT MOD binding posts of the generator.

(2) Switch the POWER switch ON and the MOD/DEV switch to the 1000 position. Decrease the BIAS ADJ R206 on the audio oscillator board until the oscillator drops out of oscillation. Increase the BIAS ADJ R206 until slightly beyond where the oscillations start again. (Note that a few seconds are required for the oscillator to stabilize each time the oscillation starts.)

(3) Attach an audio counter to the EXT MOD binding posts and measure the frequency of oscillation. Adjust the FREQ ADJ R207 for exactly 1000 Hertz on the counter.

(4) Readjust the BIAS ADJ R206 as in steps (1) and (2) and test the starting of the oscillator by switching the MOD/DEV switch in and out of the 1000 position. If the oscillator is sluggish starting, advance the BIAS ADJ R206 slightly.

(5) Observe the waveshape of the 1000 Hz sinusoid on the oscilloscope. The waveshape should be undistorted and greater than 3.5 volts peak-to-peak.

(6) Connect a harmonic distortion analyzer to the EXT MOD binding posts. Harmonic distortion should measure less than 0.5%.

p. Saw-Tooth Board Test

(1) Attach a direct-coupled oscilloscope to the EXT MOD binding posts.

(2) Switch the POWER switch ON and the MOD/DEV switch to the "saw-tooth" position.

(3) Observe the waveform of the saw-tooth as viewed on the oscilloscope. The saw-tooth waveform should be linear providing that the oscilloscope sweep circuit is also suitable linear.

(4) Advance the deviation control to maximum. The reading should be well beyond full scale on the signal generator meter. The amplitude of the saw-tooth as measured on the oscilloscope should be greater than 3 volts peak-to-peak.

PARTS LIST

REFERENCE SYMBOL	MOTOROLA PART NO.	DESCRIPTION
C801	1P984305A55	CAPACITOR, fixed, pl values stated
C802	1P984305A86	4.40 VAR
C803	1P984305A87	2.25 VAR
C804, 805	21P84305A58	1000; feedthru
C806	21P84305A89	47 +5%
C807, 812	21P84305A90	10K; CMV
C808	21P84305A91	10 a10%; NPO
C809	21P84305A92	1000; CMV
C810, 811, 814	21P84305A93	.22 +20%; mylar
C813	21P84305A94	.33 +5%
E801	65P84305A33	LAMP, incandescent 120 v; 3 w
J801	90855268	CONNECTOR, receptacle BNC type
L801	24P84305A95	COILS 2.8-4.2 MHz
L802	24P84305A96	4.1-6.0 MHz
L803	24P84305A97	6.0-7.2 MHz
L804	24P84305A98	6.7-7.0 MHz
CR01, 822, 893	48P84305A12	TRANSISTOR, (SEE NOTE) N-P-N type 2N4123
R801	6R6410	RESISTOR, fixed, 10%, 1/2 w unless stated
R802	6R6397	33K
R803	18P84305A99	22K
R804	18P84305A01	50
R805	6R5483	27
R806	6R6048	47K
R807	6R2034	15
R808, 813	6R6117	5.4K
R809	6R6291	560
R810	6R6031	100K
R811	6R394	1.2K
R812	6R6398	1.2K
R814	6R8330	150K
R815	6R8330A02	13K +5%
R816	6R6328	100
R817	18P84305A23	500; var.
S801, A, B, C, D	40P84306A03	SWITCH, rotary
V801, 802		TUBE, type 6DV4

NOTE:

Replacement transistors must be ordered by Motorola part number only for optimum performance.

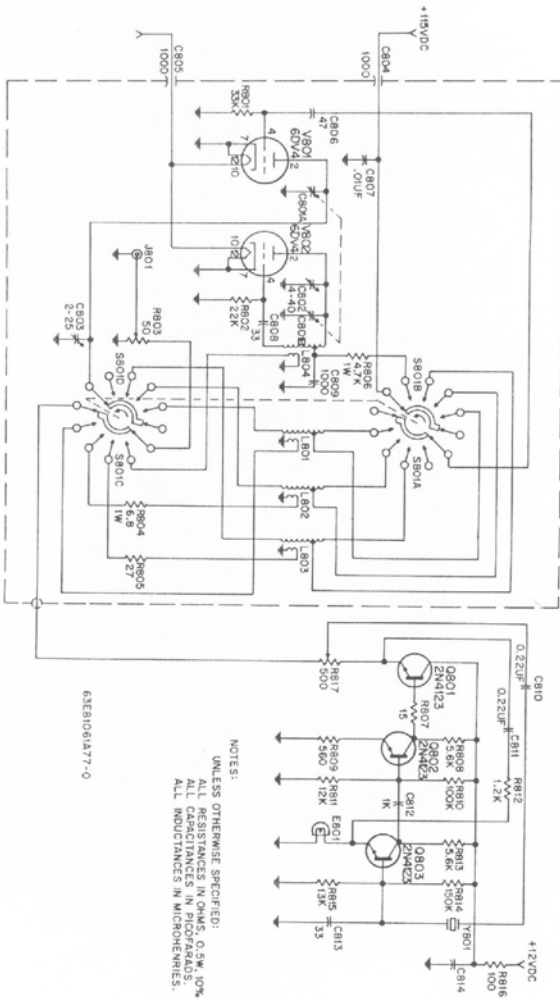

NOTES:
UNLESS OTHERWISE SPECIFIED:
ALL RESISTANCES IN OHMS, 0.5W, 10%
ALL CAPACITANCES IN P.F., 5%
ALL INDUCTANCES IN MICROHENRIES.

PARTS LIST SHOWN ON
FRONT OF THIS DIAGRAM

Intermediate Frequency and Crystal Oscillator

Schematic Diagram

Motorola No. 63E81061A77-0

9/8/69-RS

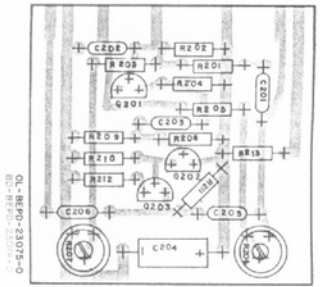

Audio Oscillator
1P84305A03

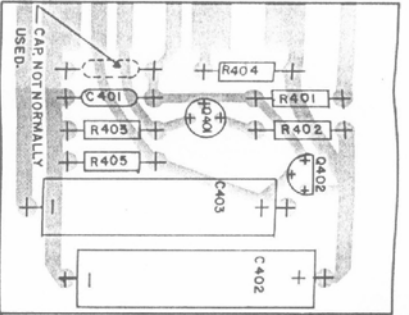

Saw-Tooth Generator
1P84305A01

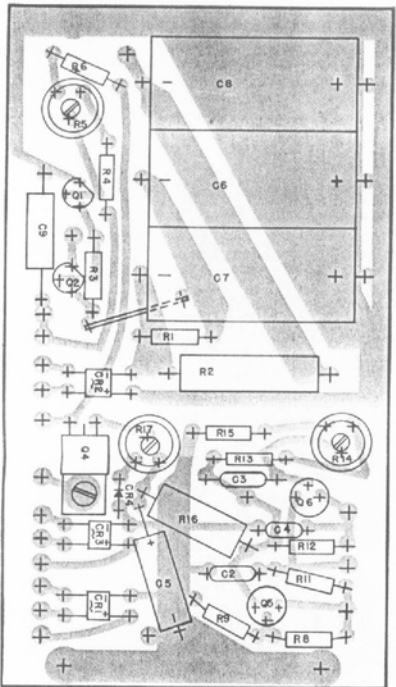

Power Supply
1P84305A07

OL-BEPD-23079-0
RD-BEPD-23079-0

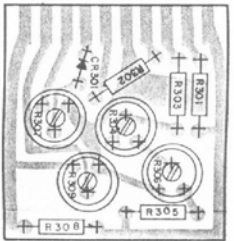

Increment Adjust
1P84305A04

OL-BEPD-23086-0
RD-BEPD-23086-0

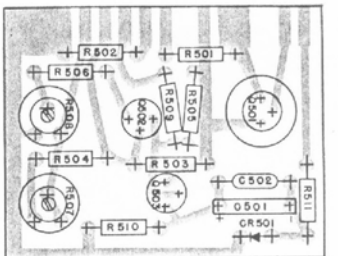

Deviation Amplifier
1P84305A02

OL-BEPD-23084-0
RD-BEPD-23084-0

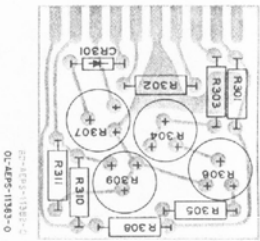

Increment Adjust
1P83554F01

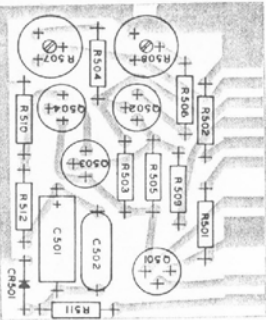

Deviation Amplifier
1P84207D63

OL-BEPD-23077-0
RD-BEPD-23077-0

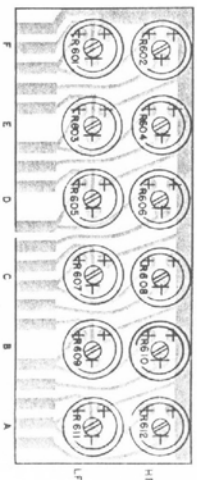

Deviation Adjust
1P84305A05

OL-BEPD-23088-0
RD-BEPD-23088-0

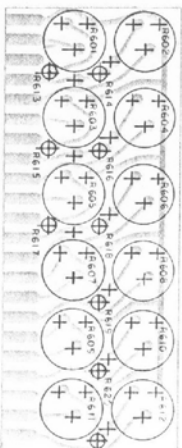

Deviation Adjust
1P83554F02 thru F05

OL-BEPD-23085-0
RD-BEPD-23085-0

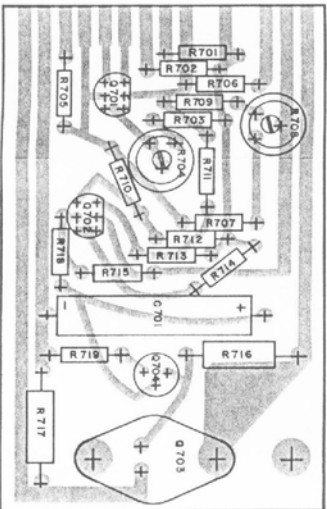

Automatic Output
1P84305A06

OL-BEPD-23077-0
RD-BEPD-23077-0

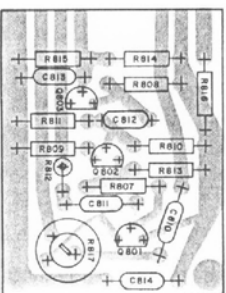

IF Xtal Oscillator
1P84306A43

OL-BEPD-23082-0
RD-BEPD-23082-0

Models S1318A, S1319A, S1320A, S1321A, & S1329A
FM Signal Generator Circuit Board Details
Motorola No. PEPD-23090-A
4/30/73-RS

DEV. ADJ.

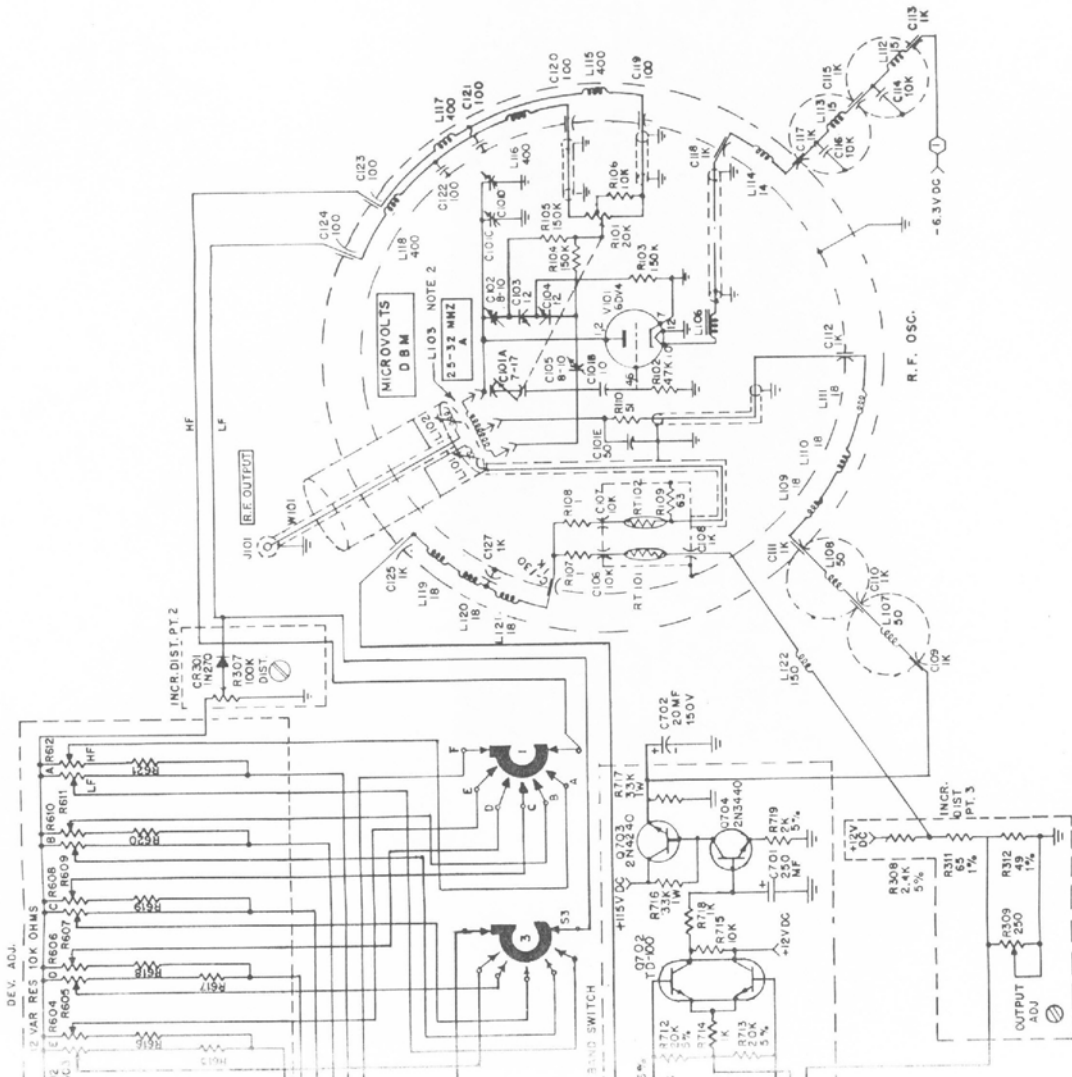

NOTES:

1. SWITCH WAFERS NUMBERED FROM PANEL. REFER TO REFERENCE CHART FOR REFERENCE NUMBERS AND TO PARTS LIST FOR VALUES. SWITCHED "COIL" ASSEMBLIES SHOWN IN CIRCLES.
2. UNLESS OTHERWISE SPECIFIED, ALL RESISTOR VALUES IN OHMS, 1/2 W, 10%; K = 1,000; M = 1,000,000.
3. ALL CAPACITOR VALUES IN PICOFARADS.
4. ALL COIL VALUES IN MICROHENRIES.

⊕ = SCREWDRIVER ADJUST
 XXXX = FRONT PANEL MARKING
 ⊗ = INTERCONNECTING CABLE CONNECTIONS

OUTPUT COIL
 DETAIL
 NOTE 2



REFERENCE CHART

REF. SYM.	FREQ.	DETAIL				
		S1318A-1 & S1319A-1	S1320A-1	S1321A-1	S1329A-1	
L103	25-32 MHz	X	X	X	X	
L104	32-41 MHz	X	X	X	X	
L105	41-54 MHz	X	X	X	X	
L124	68-88 MHz	-	Y	Y	-	
L125	88-115 MHz	-	-	X	-	
L106	130-175 MHz	Y	Y	Y	Y	
R111	400-475 MHz	Z	Z	Z	Z	
C129	890-960 MHz	Z	-	-	-	
R113	470-512 MHz	Z	-	-	-	

MODEL CHART

MODELS	BAND AND FREQ. RANGE				
	A	B	C	D	E
S1318A-1, S1319A-1	25-32 MHz	32-41 MHz	41-54 MHz	130-175 MHz	400-470 MHz
S1320A-1	25-32 MHz	32-41 MHz	41-54 MHz	68-88 MHz	130-175 MHz
S1321A-1	25-32 MHz	32-41 MHz	41-54 MHz	68-88 MHz	88-115 MHz
S1329A-1	25-32 MHz	32-41 MHz	41-54 MHz	130-175 MHz	400-470 MHz

EPS-11816-O

LATER VERSION

FOR EARLIER VERSION, REFER TO SCHEMATIC DIAGRAM 63E81061A76

PARTS LIST SHOWN ON BACK OF THIS DIAGRAM
 S1318A-1, S1319A-1, S1320A-1, S1321A-1, & S1329A-1

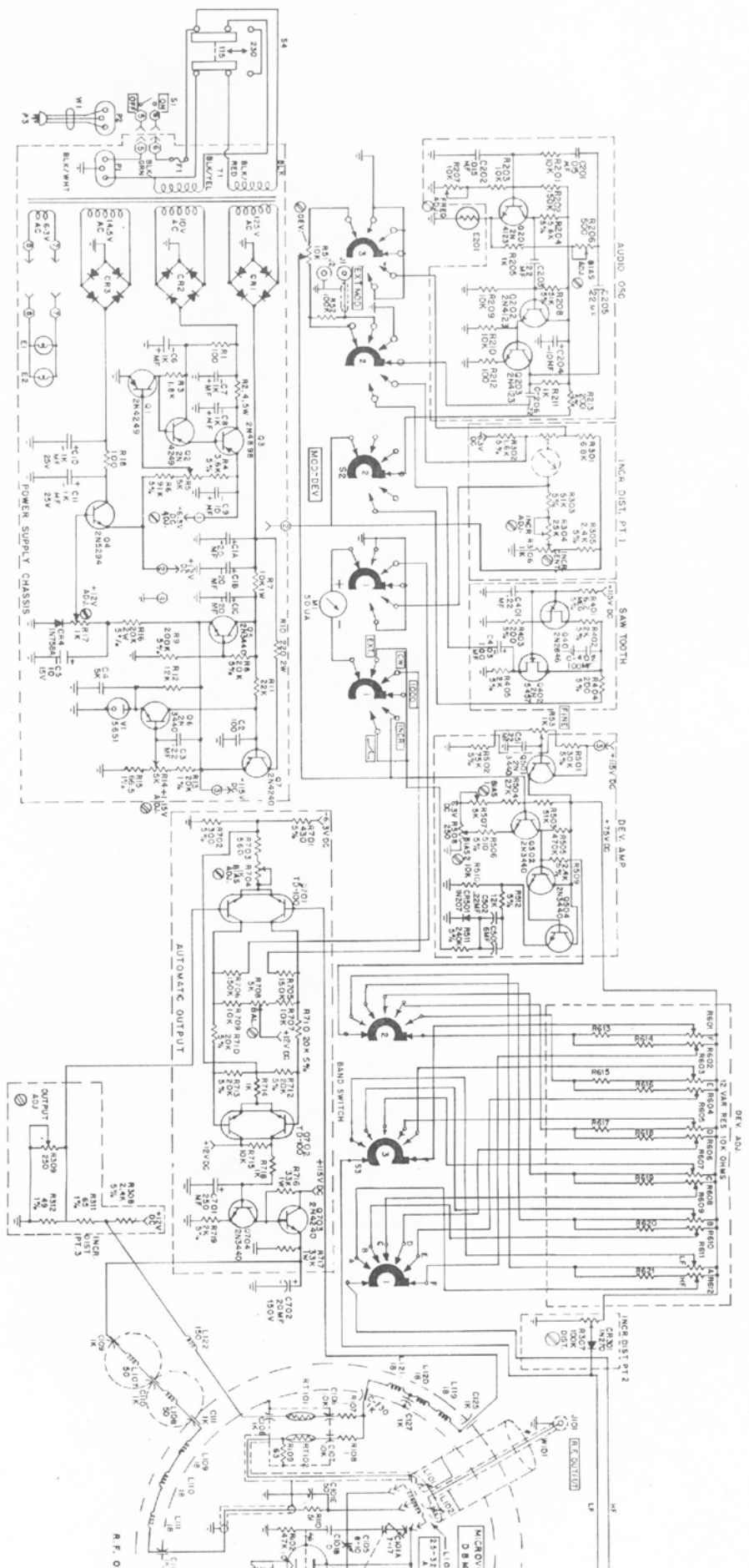

LATER
FOR EARLIER
SCHEMATIC DR

PARTS LIST

S1318A FM Signal Generator
S1319A FM Signal Generator
S1320A FM Signal Generator
S1321A FM Signal Generator

EBD-23191-0

Table with columns: REFERENCE SYMBOL, MOTOROLA PART NO., DESCRIPTION. Contains parts for capacitors, resistors, coils, and miscellaneous components.

Table with columns: REFERENCE SYMBOL, MOTOROLA PART NO., DESCRIPTION. Contains parts for meters, transistors, resistors, and miscellaneous components.

Table with columns: REFERENCE SYMBOL, MOTOROLA PART NO., DESCRIPTION. Contains parts for ear-tooth generator, audio oscillator, and other specialized modules.

NOTE:

Replacement diodes and transistors must be ordered by Motorola part number only for optimum performance.

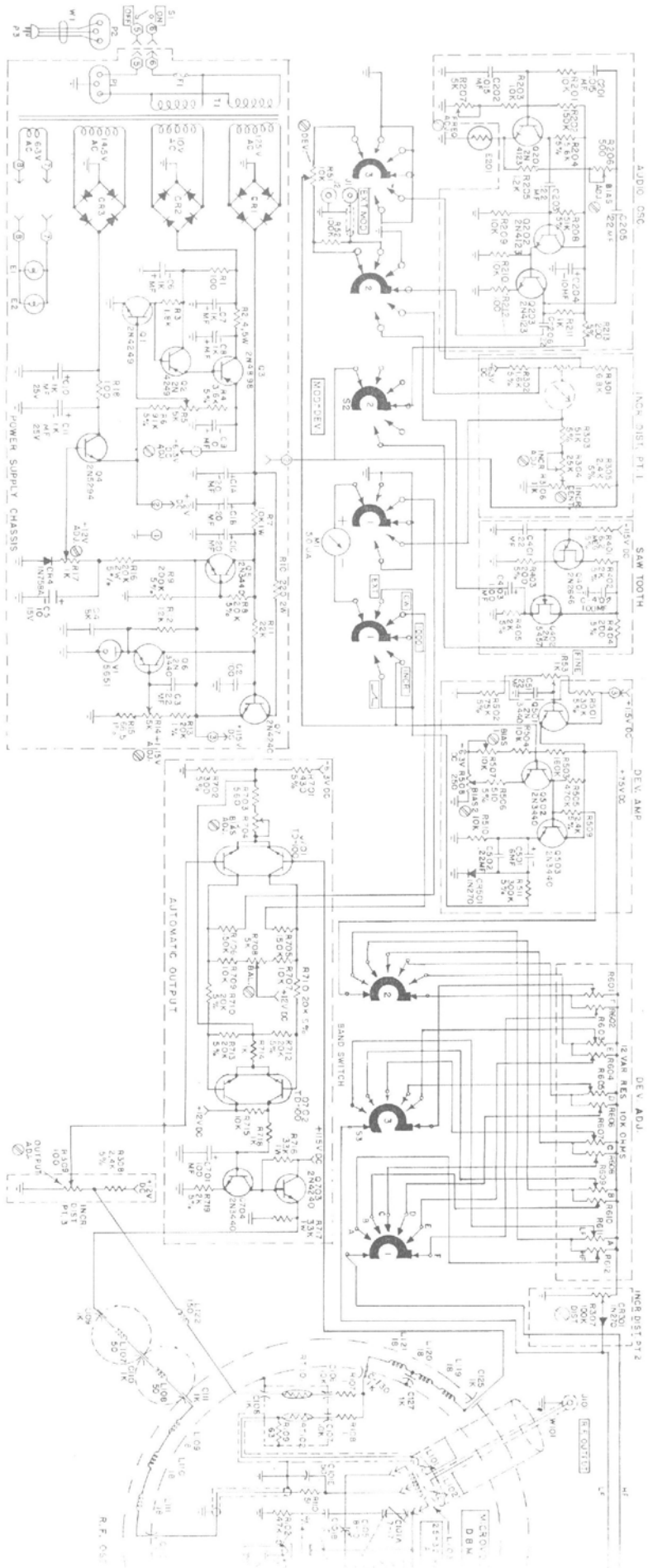

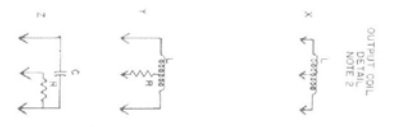
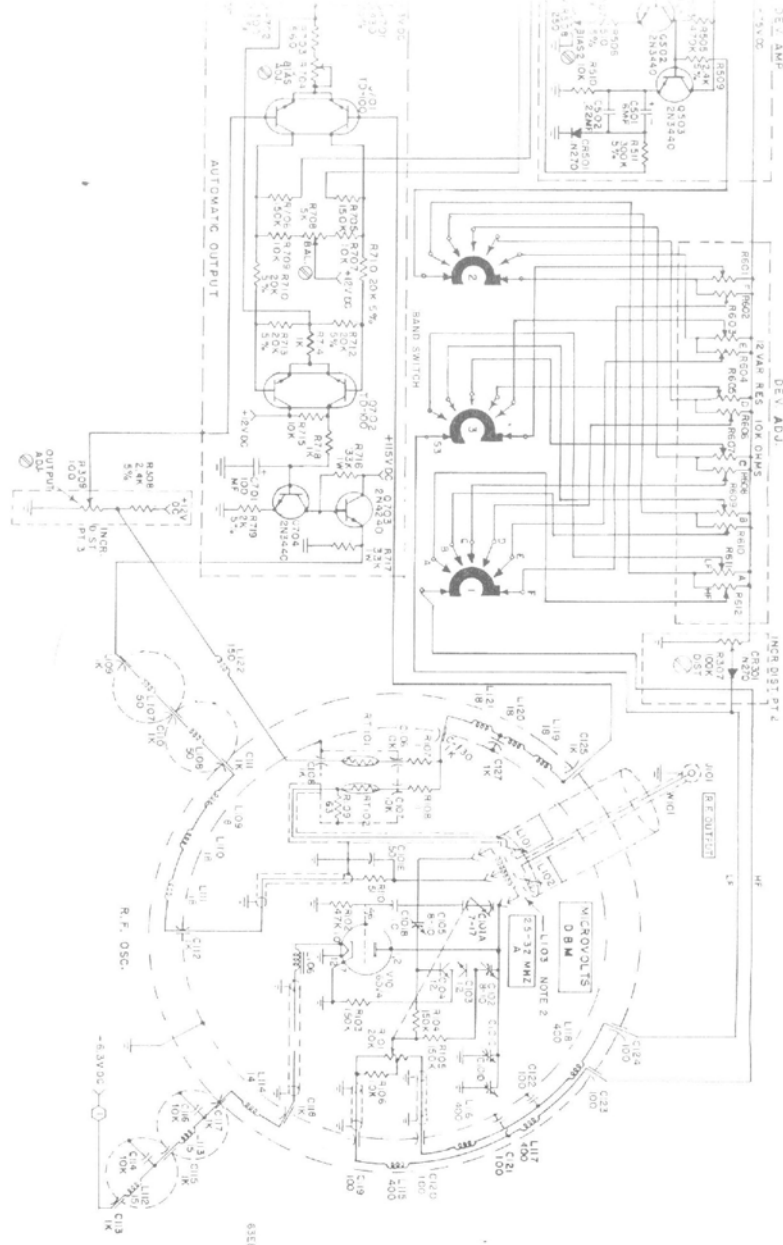

- NOTES:
1. SWITCH WATERS NUMBERED FROM PANEL.
 2. REFER TO REFERENCE CHART FOR REFERENCE NUMBERS AND SYMBOLS IN COIL DETAILS.
 3. UNLESS OTHERWISE SPECIFIED.
 4. ALL RESISTOR VALUES IN OHMS, 1/2 W., 10% R ± 1, 500; K ± 1, 500; M ± 1, 500; 600.
 5. ALL COIL VALUES IN MICROHENRES.
 6. SYMBOLS:
 - ⊕ = SCREW DRIVER ADJUST
 - ⊖ = SCREW DRIVER ADJUST
 - ⊗ = INTERCONNECTING CABLE CONNECTIONS

REFERENCE CHART

REF. SYM.	PERIOD.	6118A & 6117M	6117M	6117M	6117A
L101	27.12 MHz	X	X	X	X
L102	42.41 MHz	X	X	X	X
L103	41.54 MHz	X	X	X	X
L104	48.88 MHz	-	Y	Y	Y
L105	88.115 MHz	-	-	X	X
L106	190.175 MHz	Y	Y	Y	Y
L107	408.475 MHz	Z	Z	Z	Z
L108	898.950 MHz	X	-	-	-

MODEL CHART

MODEL	A	B	C	D	E	F
6118A, 6117M	27.12 MHz	42.41 MHz	41.54 MHz	48.88 MHz	88.115 MHz	190.175 MHz
6117M	27.12 MHz	42.41 MHz	41.54 MHz	48.88 MHz	88.115 MHz	190.175 MHz
6117A	27.12 MHz	42.41 MHz	41.54 MHz	48.88 MHz	88.115 MHz	190.175 MHz

PARTS LIST SHOWN ON
 BACK OF THIS DIAGRAM
 6118A, 6117M, 6117A, and 6117A
 FM Signal Generator
 Schematic Diagram
 Motorola No. 63E81061A76-A
 4/30/73-RS

This document was created with Win2PDF available at <http://www.daneprairie.com>.
The unregistered version of Win2PDF is for evaluation or non-commercial use only.